



LOCATION MATTERS
MANUFACTURING BUILDING
9781 86th Avenue N
Maple Grove, MN 55369
For Sale



REDUCED SALE PRICE: \$1,400,000

50 South 6th Street
Suite 1418
Minneapolis, MN
612.332.6600
www.upland.com

*Look Upland. Where Properties
& People Unite!*

CHAD STURM
612.436.1122
CHAD@UPLAND.COM

ADDRESS	9781 86th Avenue North
CITY, STATE	Maple Grove, MN 55369
BUILDING SIZE	8,500 SF
LOT SIZE	0.60 Acres
SALE PRICE	\$1,400,000
ROOF AGE	2019 (6 Years Old)
YEAR BUILT	1986
COUNTY	Hennepin
CEILING HEIGHT	14 Feet
POWER	400-Amp 3-Phase; 100-Amp 120-SF (Bus Duct Power)
LOADING	1 Dock with Leveler (10'x10') & 2 Drive-Ins (10'x12')
SPRINKER	Not Sprinklered
ZONING	Industrial

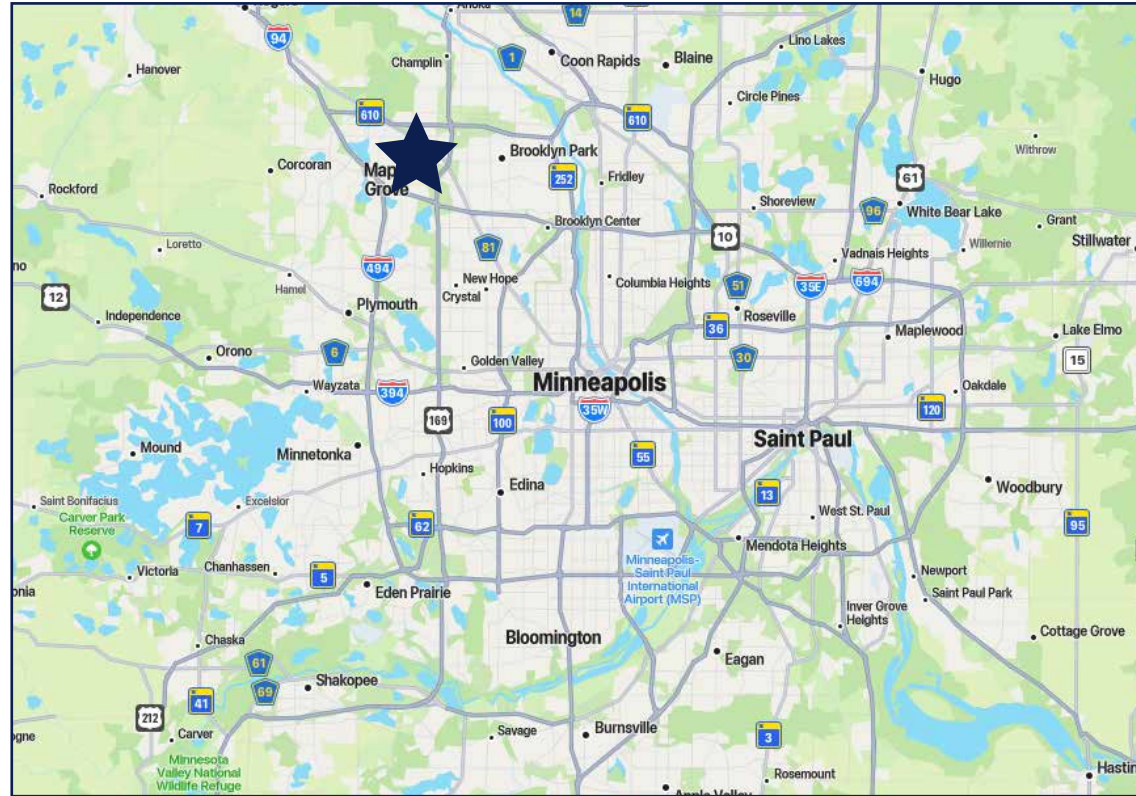

HIGHLIGHTS

- The property is well located in Maple Grove, MN within the East Maple Grove Industrial Park.
- Easy Access with close proximity to Hwy 169 and Hwy 694/494/610 freeway systems.
- Close proximity to both Minneapolis and St. Paul's Central Business Districts.
- Hard to find Free-Standing Single User building.
- Within minutes of both the Maple Grove Arbor Lakes retail area & Osseo's "Main Street" area. Providing an abundance of retail & restaurant opportunities.

2025 DEMOGRAPHICS	1-MILE RADIUS	3-MILE RADIUS	5-MILE RADIUS
POPULATION	4,445	69,745	205,531
MEDIAN AGE	40.0	38.1	38.3
MEDIAN HH INCOME	\$101,793	\$98,434	\$100,613
AVERAGE HH INCOME	\$127,629	\$124,413	\$130,614

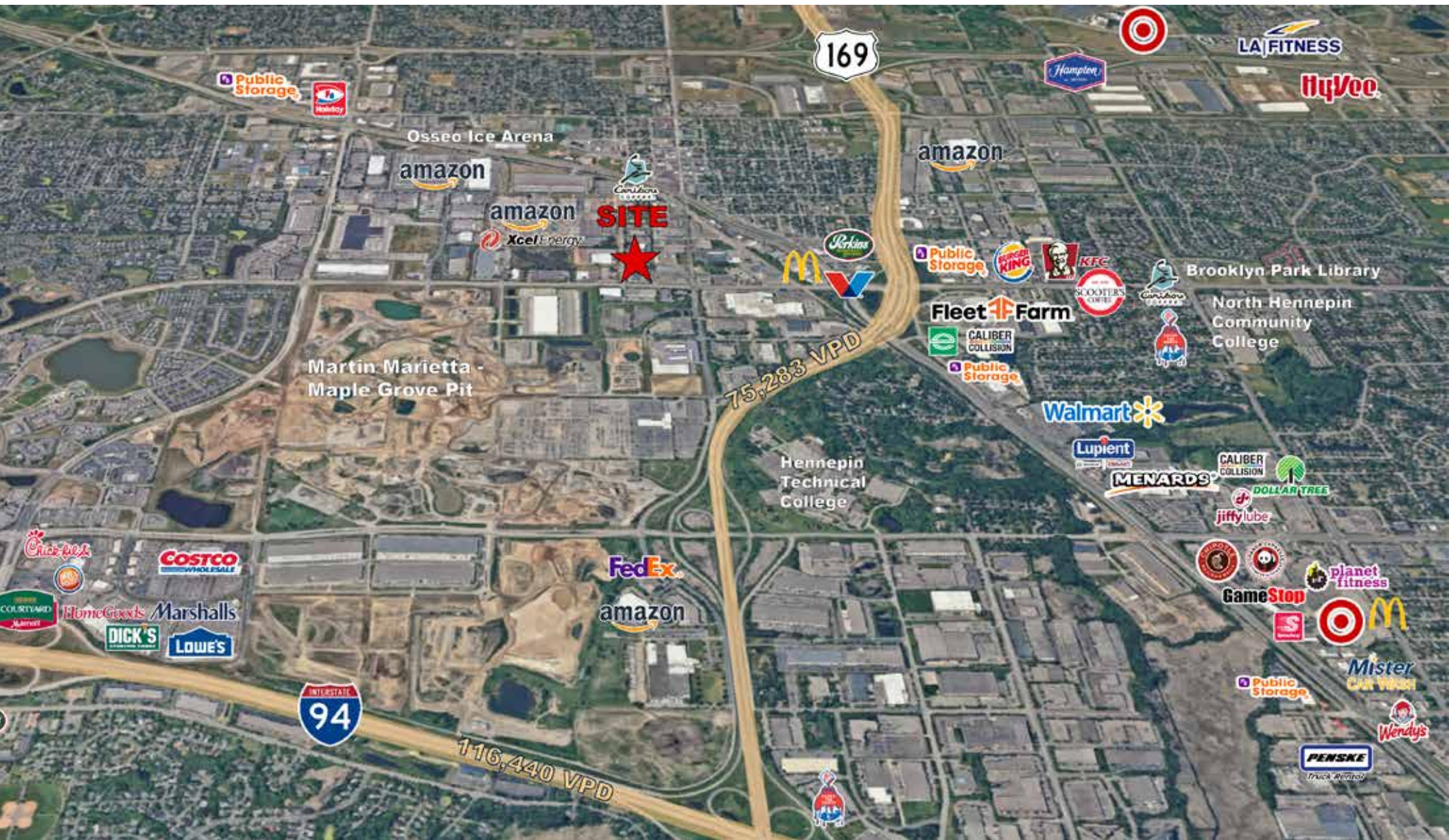

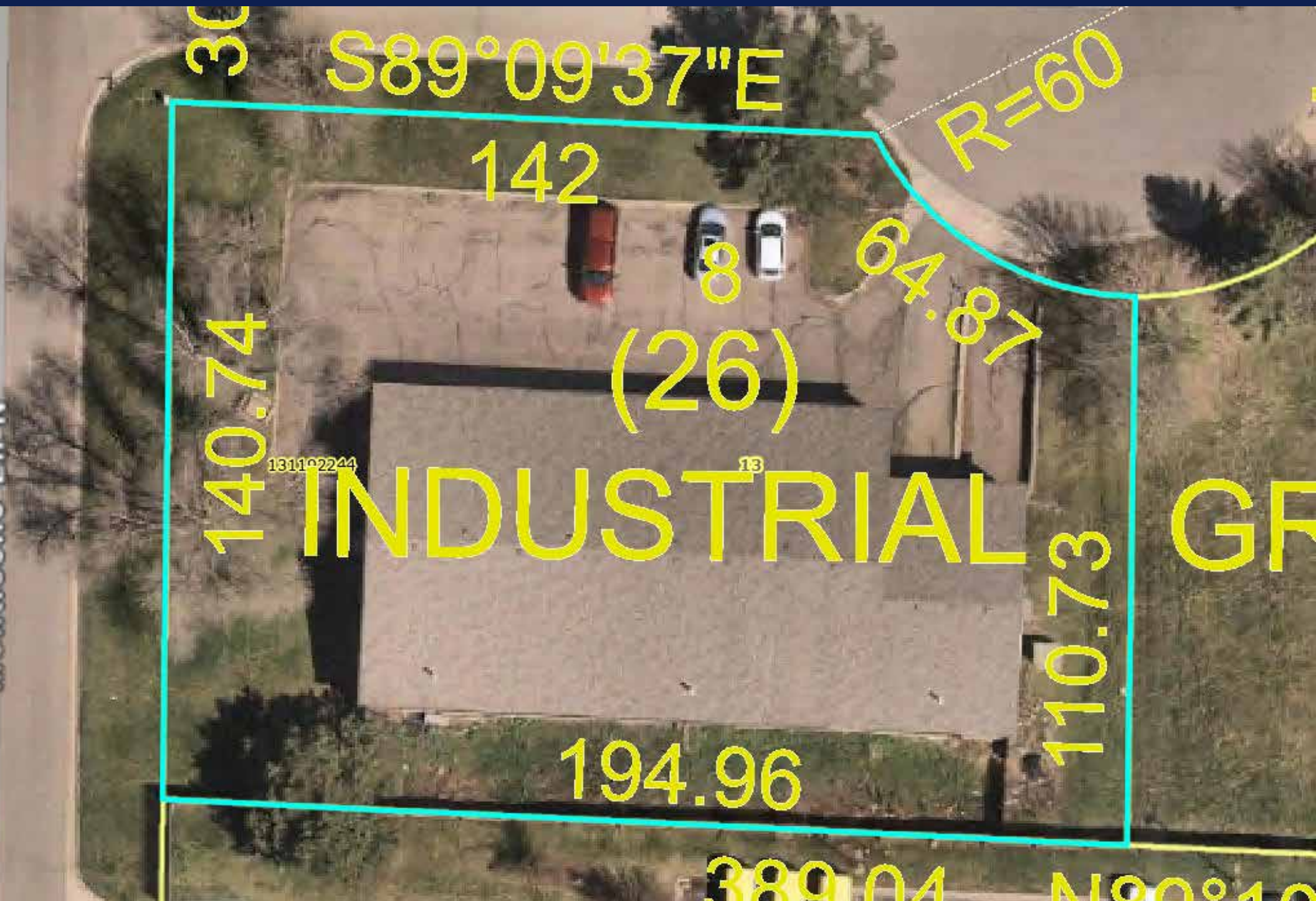

30

S89°09'37"E

R=60

142

8

64.87

140.74

(26)

131102244

13

INDUSTRIAL

GR

110.73

194.96

389.04

N00°10'

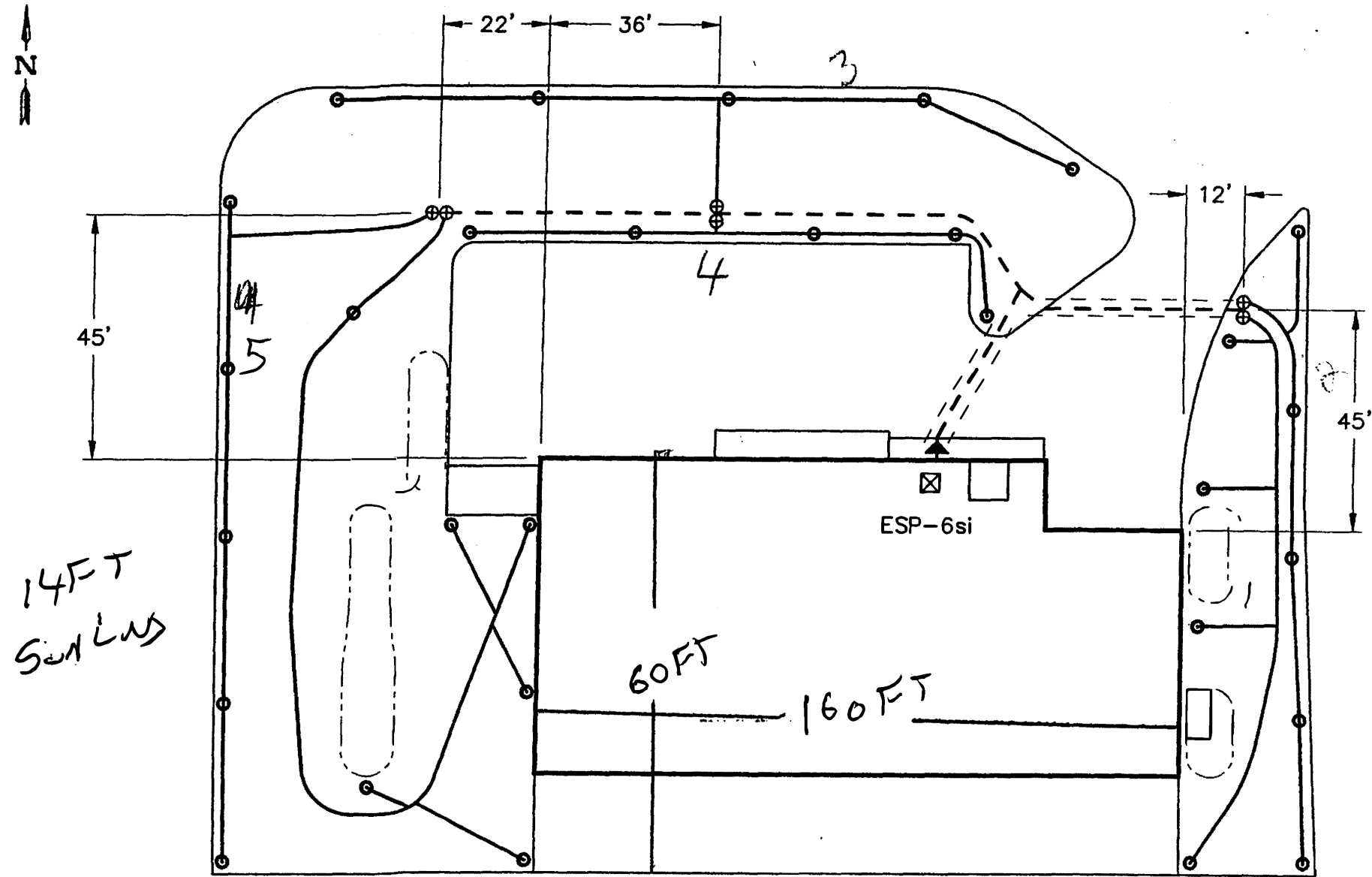
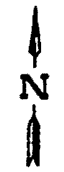

	Vacuum Breaker		Valve
	Controller		Rotor Head
	Poly Main		
	Poly Lateral		

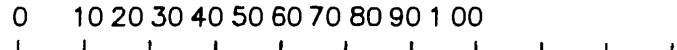

APPROX. SCALE: 1" = 30' (1:360)

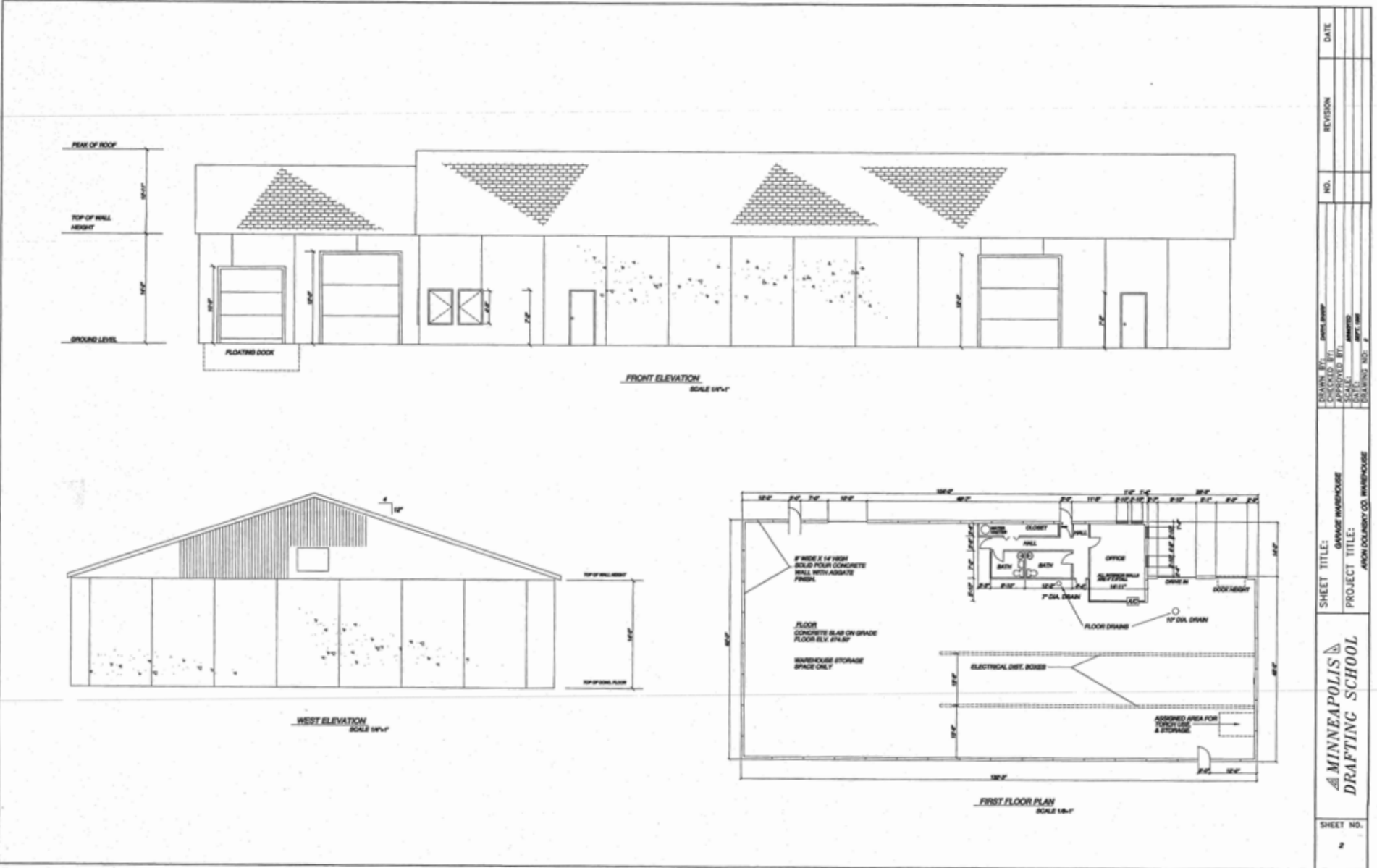

NO.	REVISION	DATE

DRAWN BY: <i>[Signature]</i>	DATE: <i>[Date]</i>
CHECKED BY: <i>[Signature]</i>	SCALE: <i>[Scale]</i>
PROJECT TITLE: GAUGE WAREHOUSE	PROJECT NO.: <i>[Number]</i>
PROJECT TITLE: ARON POLAROID CO. WAREHOUSE	PROJECT NO.: <i>[Number]</i>

MINNEAPOLIS DRAFTING SCHOOL
SHEET NO. 2

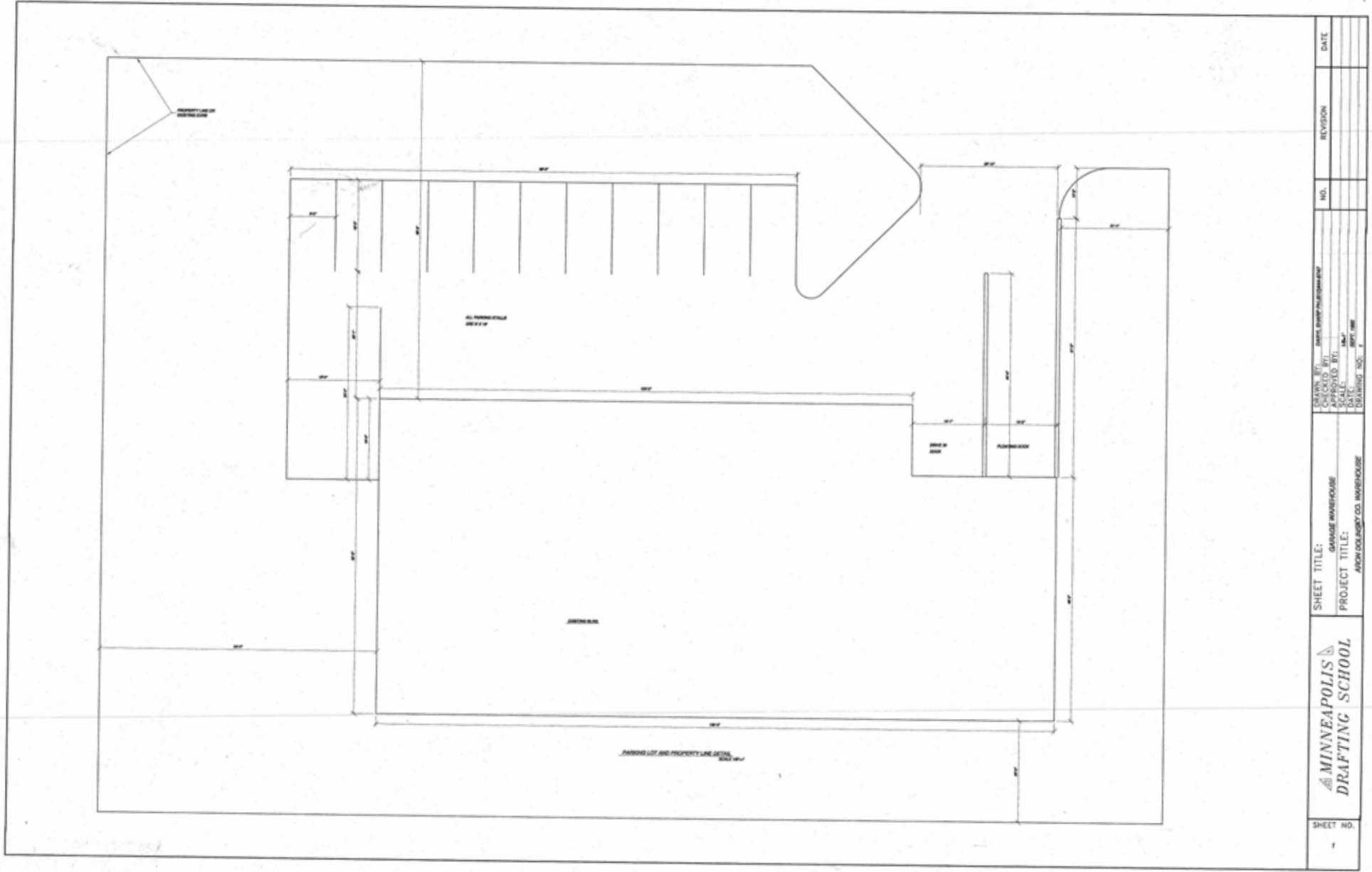

DESIGN BY: MARK WILSON/ARCHITECTURE	NO.	REVISION	DATE
CHECKED BY:			
APPROVED BY:			
DRAWN BY:			
DRAWING NO.:			
SHEET TITLE: GARAGE MANUFACTURE			
PROJECT TITLE: ARON DOLANBYT CO. MANUFACTURE			
 MINNEAPOLIS DRAFTING SCHOOL			
SHEET NO.	1		







UPLAND

REAL ESTATE GROUP, INC.

50 South 6th Street
Suite 1418
Minneapolis, MN
612.332.6600

CHAD STURM
612.436.1122
CHAD@UPLAND.COM

THIS INFORMATION HAS BEEN SECURED FROM SOURCES WE BELIEVE TO BE RELIABLE, BUT WE MAKE NO REPRESENTATIONS OR WARRANTIES, EXPRESSED OR IMPLIED, AS TO THE ACCURACY OF THE INFORMATION. REFERENCES TO SQUARE FOOTAGE OR AGE ARE APPROXIMATE. UPLAND HAS NOT REVIEWED OR VERIFIED THIS INFORMATION. BUYER MUST VERIFY THE INFORMATION AND BEARS ALL RISK FOR ANY INACCURACIES.